

imc Meßsysteme GmbH

Isolation with imc CRONOS*flex*

Individual channel-wise and block isolation

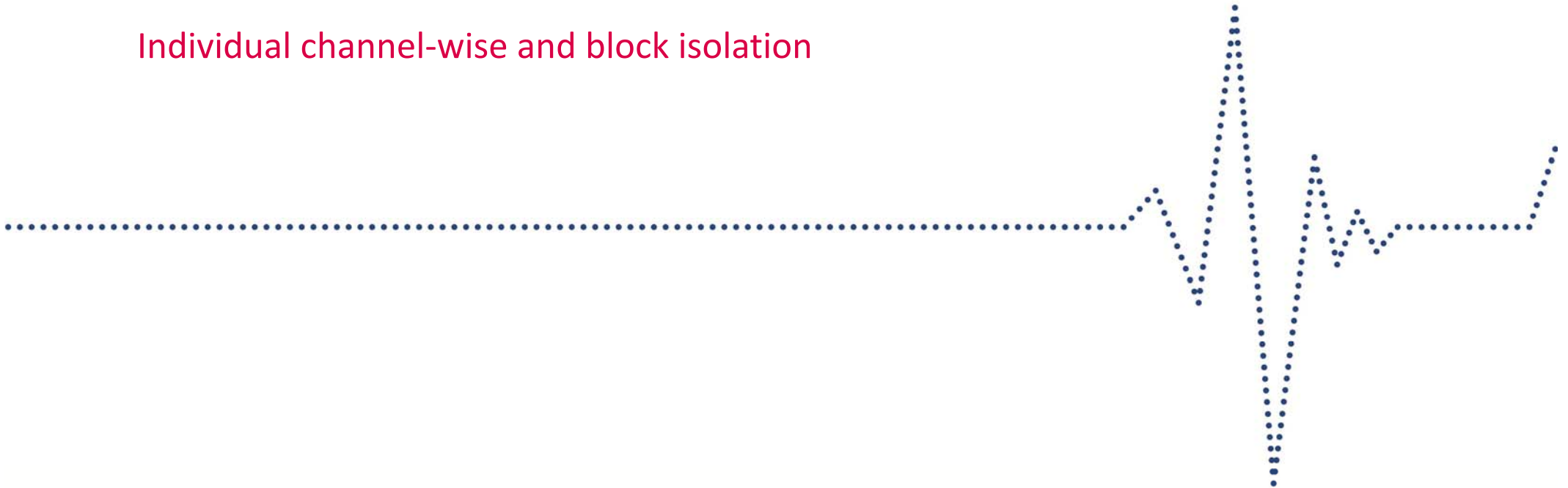

Characterizing “isolation”:

Individual vs. block isolation

UNI-4: most flexible (individually isolated main amps)

UNI2-8 : competing with isolated bridge amps

ISO2-8: optional sensor supply

HRENC, ICPU-8: benefit from ground loop suppression

Review of Specs (TD)

Summary

Galvanic isolation

- High impedance (GΩ range)
- Can be checked with handheld multimeter instrument

Block isolation

- Isolation of entire functional blocks
- Across multiple channels
- Especially: isolation with respect to: Case / CHASSIS / GND / Power supply

Individual channel-wise isolation

- Channels mutually isolated

Decoupled channels

- Nonreactive, independently configurable, decoupled in events of error or output short circuit, etc.

Overvoltage protection

- Overvoltage on measurement inputs
- Differential mode (instead of common mode)
- Not to be confused with “Isolation voltage”
- Not to be confused with Common mode noise rejection ratio (CMRR, IMR)

Isolation UNI-4

CRFX/UNI-4 module components and levels of isolation



imc CRONOSflex UNI-4

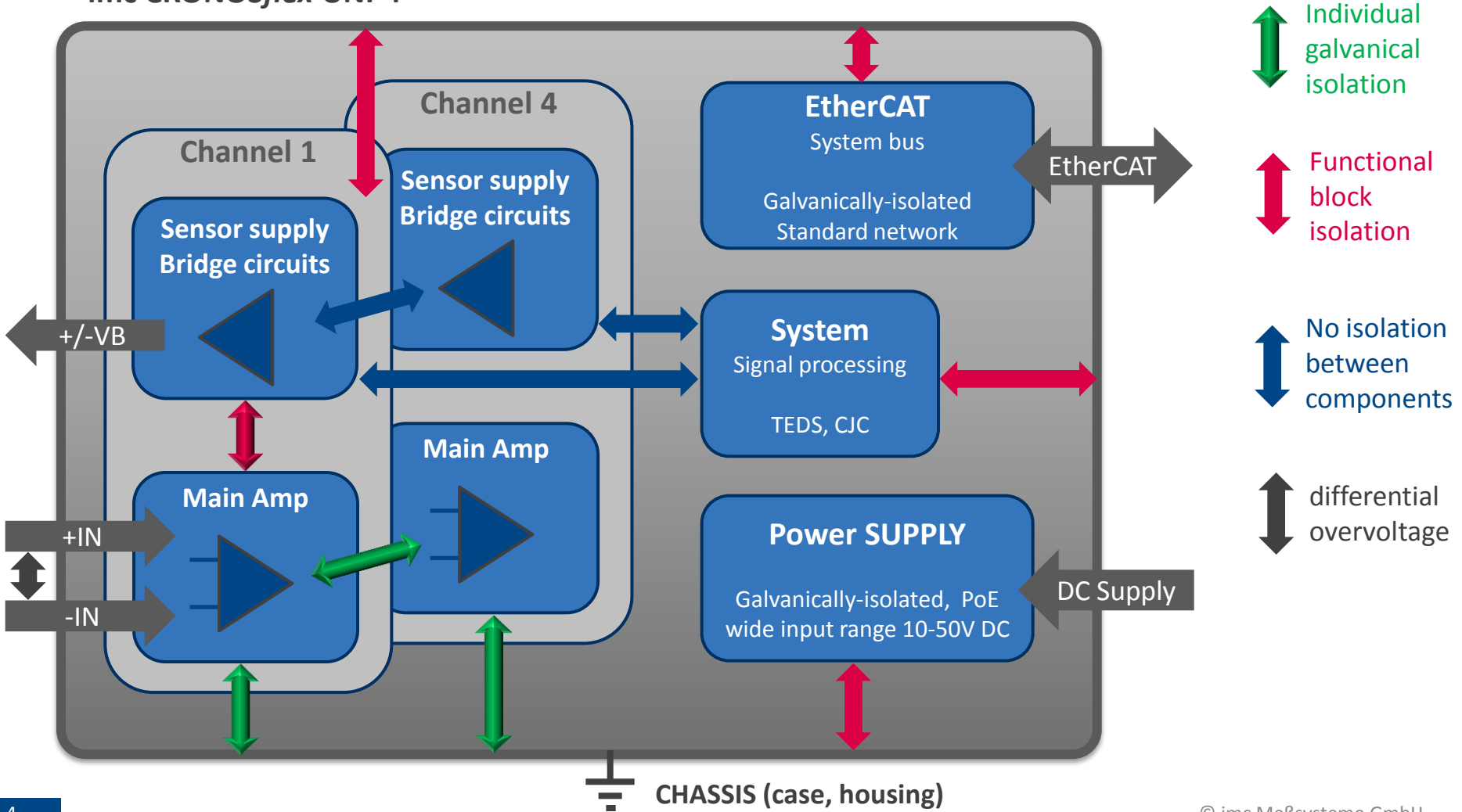

Isolation with UNI-4

UNI-4 module for CRFX: components and levels of isolation - Overview



Main amplifier

- **Individual galvanic isolation** - for voltage and thermocouple mode
- When used in bridge mode: “neutralized” - block isolation of sensor supply and bridge circuitry applies!

Sensor supply and bridge mode

- **TD specs: declared as “Block isolation”**
- Functional block isolation to CHASSIS (case) for entire 4-channel circuitry as a unit including bridge circuits (half/quarter bridge, shunt calibration etc.)
- Sensor / bridge supply with decoupled and individual settings (2.5V..15V) - but no individual isolation!

System functions

- Functional block isolation to CHASSIS (case)
- Hidden internal functionalities
- TC cold junction compensation, TEDS interface, signal processing

Power supply

- Isolated power supply of module, wide range DC input, PoE capabilities
- Avoiding ground loops in wide area distributed setups

EtherCAT

- CRFX system bus, inherently isolated standard network technology
- Secure signal integrity and ground loops in wide area distributed setups

Isolation for CRFX-UNI-4

In detail: main **voltage amplifier**



- Functions
 - Main signal path for voltage and thermocouple mode
 - Individual galvanic isolation
 - Fully isolated design with individual ADCs and isolated data couplers
- Rating
 - Explicitly suited for high common mode levels: 60V rated / 300V tested
 - Moderate 60 V rating – mainly for reasons of formal certification issues (human safety)
- Applications
 - Thermocouples mounted with galvanic connection to elevated voltage levels
 - Differential 20 mA current via external shunt plug (ACC/DSUB-I2): fully isolated!
 - Once bridge mode is involved and/or extended input circuitry options used:
refer to: block isolation of sensor supply and bridge circuitry

Isolation with CRFX-UNI-4

In detail: sensor supply and **bridge mode**





- Hardware design
 - Sensor supply and all extended bridge circuitry: common internal supply and reference
 - No individual isolation channel-by channel
 - But: common and global **block isolation** to CHASSIS (case) for entire 4-channel circuitry
- Bridge supply “-VB1” .. “-VB4” interconnected to same potential, but isolated from
 - CHASSIS, case
 - Protective earth, PE, wall adapter GND
 - External machinery, metal structures and installations
- “Isolation” vs. “Decoupling”:
 - Sensor / bridge supply allow channel-wise individual settings (2.5V..15V)
 - Completely decoupled in case of failure / short circuit
- Block isolation applies to all extended input options:
 - Half/quarter bridge
 - Shunt calibration
 - Single ended voltage mode
 - Single ended 20 mA current input (internal shunt, return path to internal GND)
 - RTD / PT100 with block isolated reference current sources

Isolation with CRFX-UNI-4

Data sheet: Modes - individually isolated vs. "non isolated" with block isolation





Measurement modes DSUB		ACC/DSUB(M)-UNI2 for all modes
<p>isolated measurement modes:</p> <p> Individual galvanical isolation</p>	<p>voltage measurement (differential)</p> <p>current measurement</p> <p>thermocouple</p>	<p>with Shunt-plug (ACC/DSUB(M)-I2)</p>
<p>non-isolated measurement modes:</p> <p> Functional block isolation</p> <p> No isolation between channels</p>	<p>voltage measurement (single-end)</p> <p>current measurement</p> <p>bridge-sensor</p> <p>strain gauges</p> <p>PT100/PT1000 (3- and 4-wire connection)</p> <p>current fed sensors (IEPE/ICP)</p>	<p>with internal Shunt</p> <p>ACC/DSUB-ICP2, ACC/DSUB-ICP-BNC</p>

Isolation with CRFX-UNI-4

TD: Definition of “individually-isolated” vs. “non-isolated” with block isolation



General		
Parameter	Value	Remarks
Isolation of voltage channels  Individual galvanical isolation	channel-wise galvanically-isolated	voltage channels isolated against each other and against system ground (housing, CHASSIS, PE), as well as against common reference and all bridge excitation voltages "-VB" Isolation with IEPE/ICP plug: depends on plug type
Bridge excitation voltage isolation  Functional block isolation  No isolation between channels	not channel-wise isolated	isolated against additional electronics (all sensor power supplies, bridge and input wiring, TEDS, etc.) with common reference ground "-VB" Block-isolated against system ground (housing, CHASSIS, PE)
Max common mode voltage isolated mode tested:	$\pm 60 \text{ V}$ 300 V (10 sec.)	against internal reference ground "-VB", against system ground (housing, CHASSIS, PE)
Max common mode voltage non-isolated mode	$\pm 10 \text{ V}$	against internal reference ground "-VB" Also for "non-isolated" mode, there is an additional global block-isolation of the entire internal measurement electronics from the housing (CHASSIS, PE)

Isolation with CRFX-UNI-4

New TDs: Specs of block isolation

Block isolation		
Parameter	Value	Remarks
Block isolation	60 V	all internal electronics isolated from the housing (CHASSIS, PE) Exception: additional individual isolated voltage channels
Isolation impedance	500 k Ω 1 nF	
Internal reference ground	-VB, GND, TEDS_GND	all channels with one common, galvanically connected reference ground
External reference ground	CHASSIS, metal housing	internal electronics as an entity, galvanically isolated from housing

Note

Block isolation for improved suppression of ground loops and related interference. Does not constitute channel-wise individual isolation. Not rated nor intended for safety of equipment and personnel.

Isolation with CRFX-UNI-4

TD: Protection against differential overvoltage



<p>Overvoltage protection (inputs +IN, -IN)</p> <p> Differential overvoltage</p>	<p>± 100 V ESD 2 kV</p> <p>transient protection: automotive load dump ISO 7636, test impulse 6</p>	<p>differential input voltage (continuous) human body model test pulse 6 with max. -250 V $R_i=30 \Omega$, $t_d=300 \mu\text{s}$, $t_r<60 \mu\text{s}$</p>
---	---	--

Isolation with CRFX-UNI-4

Data sheet: Power supply and EtherCAT system bus



Power supply of the module		
Parameter	Value	Remarks
Input supply voltage	10 V to 50 V DC	
Power consumption	10 W	10 V to 50 V DC
Isolation	60 V	nominal isolation specification of the supply input
Power-over EtherCAT (PoE)	42 V to 50 V DC	supply via EtherCAT network cable



Functional
block isolation

Terminal connections of the module		
Parameter	Value	Remarks
EtherCAT connection	2x RJ45	system bus for distributed imc CRONOSflex components
Input supply plug (female)	LEMO.EGE.1B.302	multicoded 2 notches for optional individually power supply
Module connector	2x 20 pin	direct connection of modules (click) supply and system bus

Isolation UNI-8

CRFX/UNI-8 module components and levels of isolation



imc CRONOSflex UNI-8

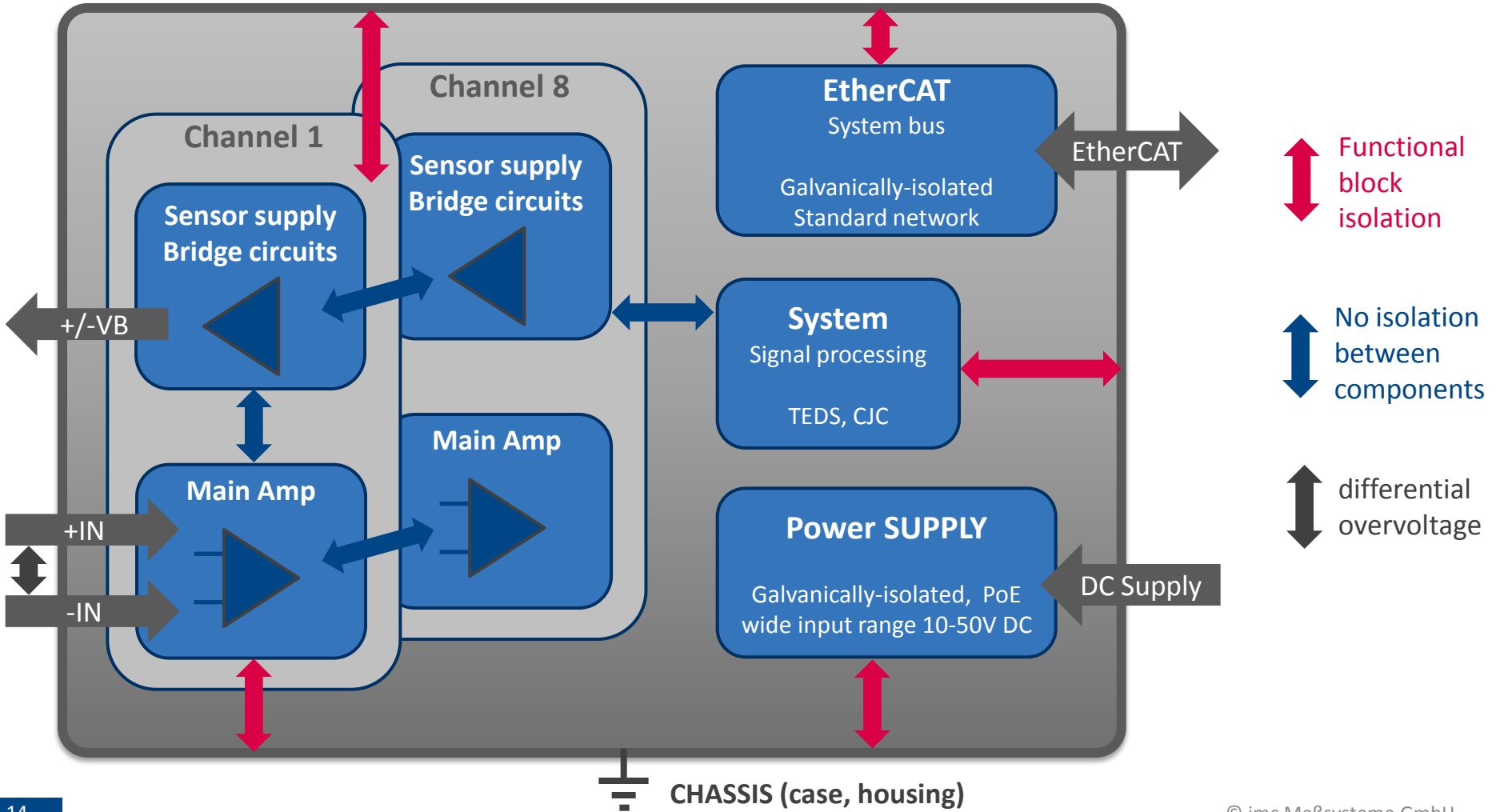

Isolation with UNI2-8

UNI-8 module for CRFX: components and levels of isolation



Main amplifier

- **No individual** galvanic **isolation** (unlike UNI-4)
- Functional block isolation for complete input – including sensor supply

Sensor supply and bridge mode

- **TD specs: declared as “Block isolation”**
- Functional block isolation to CHASSIS (case) for entire 8-channel circuitry of analog front end
- **No individual settings** for sensor / bridge supply (2.5V..24V) – common global choice!

System functions

- Functional block isolation for TC cold junction compensation, TEDS interface, signal processing
- Hidden internal functionalities: uniform concept for most CRFX amplifiers

Power supply

- Isolated power supply of module, wide range DC input, PoE capabilities
- Uniform concept for all CRFX amplifiers: suited for distributed topologies
- Avoiding ground loops in wide area distributed setups

EtherCAT

- CRFX system bus, inherently isolated standard network technology
- Uniform concept for all CRFX amplifiers: suited for distributed topologies
- Secure signal integrity and ground loops in wide area distributed setups

Isolation with CRFX-UNI-8

New TDs: explicitly specifying block isolation

Block isolation		
Parameter	Value	Remarks
Block isolation	60 V	all internal electronics isolated from the housing (CHASSIS, PE)
Isolation impedance	500 k Ω 1 nF	
Internal reference ground	-VB, GND, TEDS_GND	all channels with one common, galvanically connected reference ground
External reference ground	CHASSIS, metal housing	internal electronics as an entity, galvanically isolated from housing

Note

Block isolation for improved suppression of ground loops and related interference. Does not constitute channel-wise individual isolation. Not rated nor intended for safety of equipment and personnel.

Devices or modules purchased before ca. 2012 do not feature block isolation.

Isolation with CRFX-UNI-8

New TDs: global sensor supply and front-end as a common block



Sensor supply				
Parameter	Value			Remarks
Configuration options	5 selectable settings			The sensor supply module always has 5 selectable voltage settings. default selection: +5 V to +24 V
Output voltage	Voltage	Current	Power	set jointly for all eight channels optional, special order: +12 V or +15 V can be replaced by +2.5 V preferred selection with 2.5 V: +2.5 V, +5.0 V, +10 V, +12 V, +24 V optional, special order: +15 V can be replaced by ± 15 V
	+1 V	580 mA	0.6 W	
	+2.5 V	580 mA	1.5 W	
	+5.0 V	580 mA	2.9 W	
	+10 V	300 mA	3.0 W	
	+12 V	250 mA	3.0 W	
	+15 V	200 mA	3.0 W	
	+24 V	120 mA	2.9 W	
	(± 15 V)	190 mA	3.0 W	
Block isolation	60 V			Isolation of the entire global sensor supply (for all 8 channels, reference ground: "-VB") as well as the internal electronics from housing (CHASSIS, PE)

Isolation ISO2-8

CRFX/ISO2-8 module components and levels of isolation



imc CRONOSflex ISO2-8

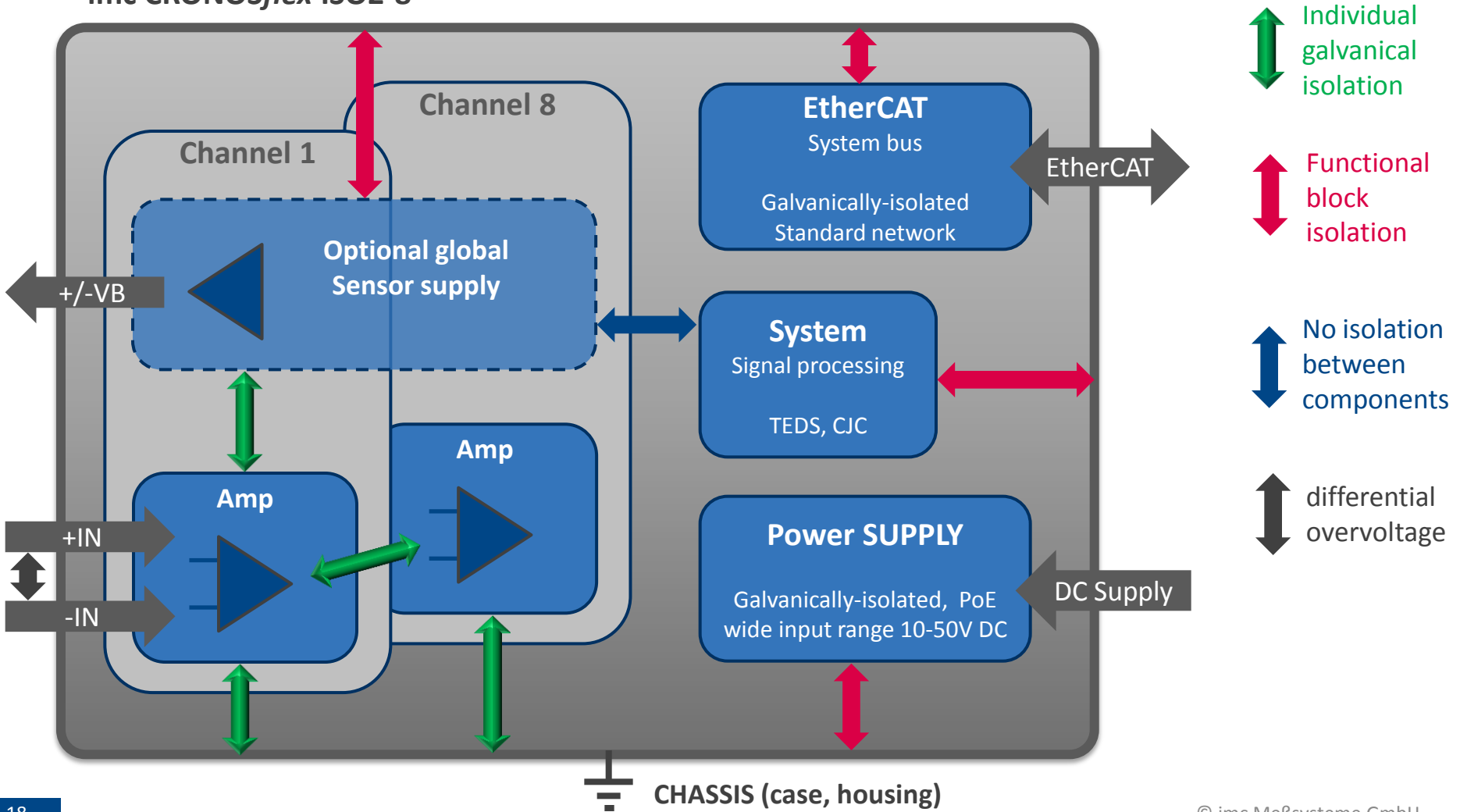

Isolation with ISO2-8

ISO2-8 module for CRFX: components and levels of isolation



- Functions
 - Full individual galvanic isolation for voltage and thermocouple mode
 - Thermocouples mounted with galvanic connection to elevated voltage levels
 - Differential 20 mA current via external shunt plug (ACC/DSUB-I4): fully isolated!
 - RTD / PT100 with block isolated reference current sources, only
 - no major restriction: Unlike TC, any RTD will always be mounted isolated to substrate (2/4 wires)
- Rating
 - Explicitly suited for high common mode levels: 60V rated / 300V tested
 - Moderate 60 V rating – mainly for reasons of formal certification issues (human safety)
- Optional sensor supply
 - ***TD specs: declared as “Block isolation”***
 - Block isolation to CHASSIS (case) for entire sensor supply unit!
 - Global sensor supply: no individual settings, common global choice!
 - Common pin on DSUB-15: used by 4 channels per plug

Block-Isolation with imc CRONOSflex (CRFX)

History of product development and specs



Block isolation

- Common global isolation of analog front end and system functions
- For all current CRFX amplifiers (*since 2012*) – *even the non-isolated* types (UNI2-8, DCB2-8, LV3-8, BR2-4, HRENC-4) !
- Initially (before 2012), block isolation was NOT activated
- TD specs had not been updated after 2012: *still formally declared as “non-isolated”*
- Because:
 - Not entirely independent, yet sufficient for ground loop suppression
 - Requires careful attention and understanding
 - Not fully “fire and forget”
 - Aiming to avoid confusion
 - Historical evolution of product development

- *Now (2014):* ***block isolation fully supported !***
fully documented
detailed specs (TD)

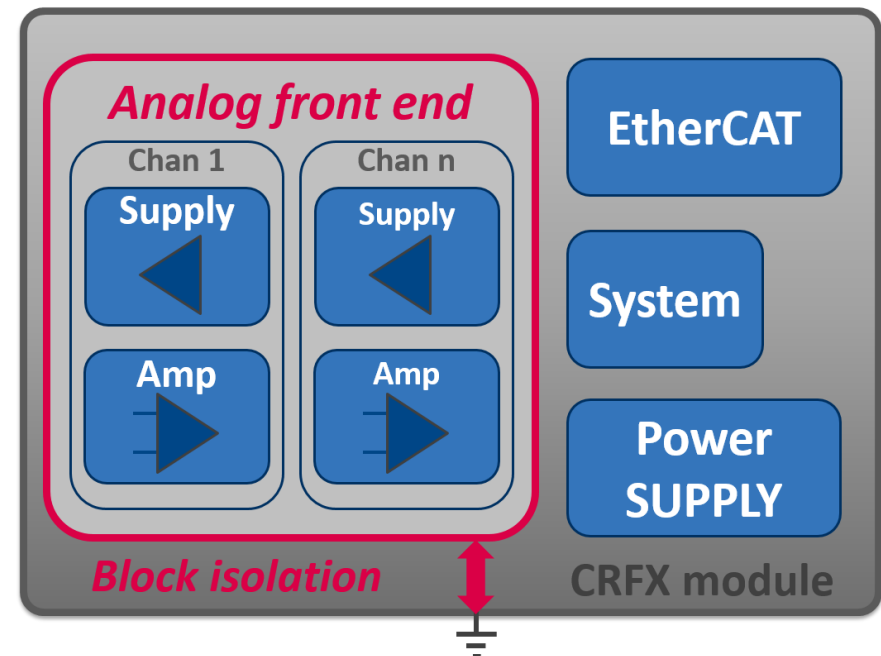

Isolation with imc CRONOSflex (CRFX)

Summary and conclusion for UNI-4 and UNI2-8



Degree of isolation

↑ Individual galvanical isolation

↕ Functional block isolation

↕ No isolation between components

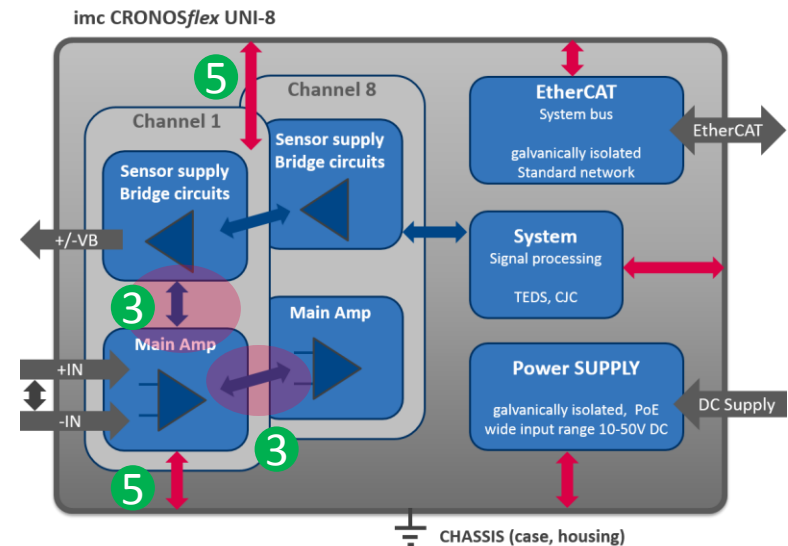
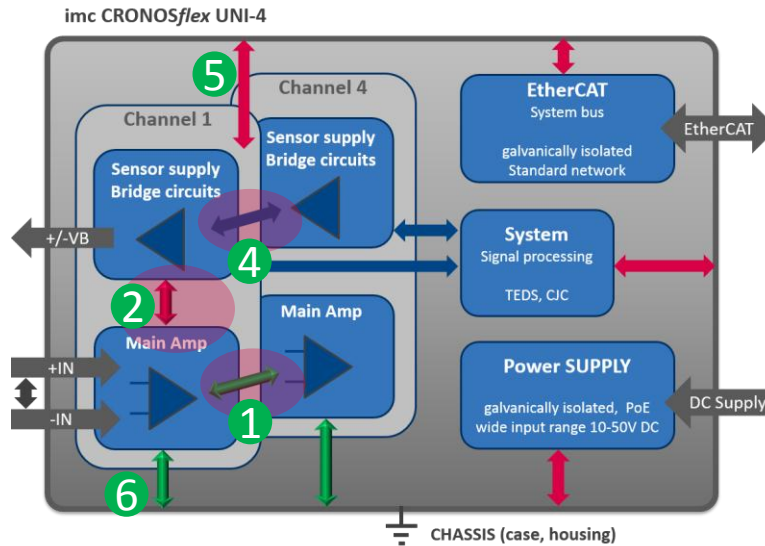

UNI-4 vs. UNI2-8 and CRFX block isolation

- 1 • UNI-4 has *individually-isolated* voltage channels
- 2 • Also isolated against the supply unit as a whole
- 3 • This is an additional degree of flexibility compared to UNI2-8
- 4 • Sensor supply and *bridge circuits* are *NOT individually* isolated
- 1 • This *neutralizes individual isolation in the case of bridge mode (1) vs. (4)*
- 5 • CRFX features “*block isolation*” of the entire front end as an additional benefit, extending beyond the properties of CRC, C-SERIES, SPARTAN
- 6 • This is not quite as comprehensive as (6) – but often *well sufficient!*

imc CRONOSflex LV3-8, BR2-4, ICPU2-8, HRENC-4

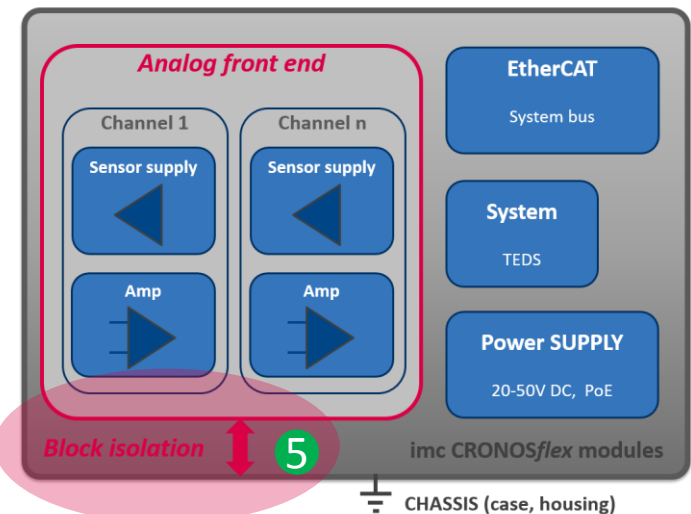

Isolation with imc CRONOSflex (CRFX)

Overview

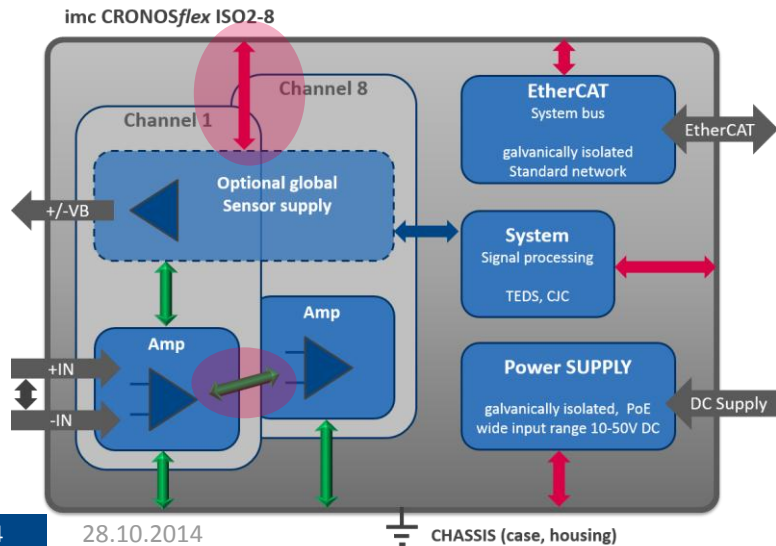
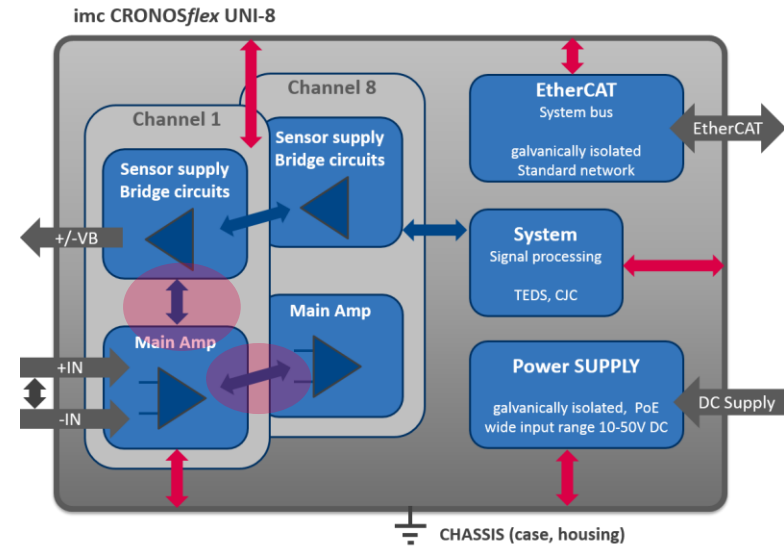
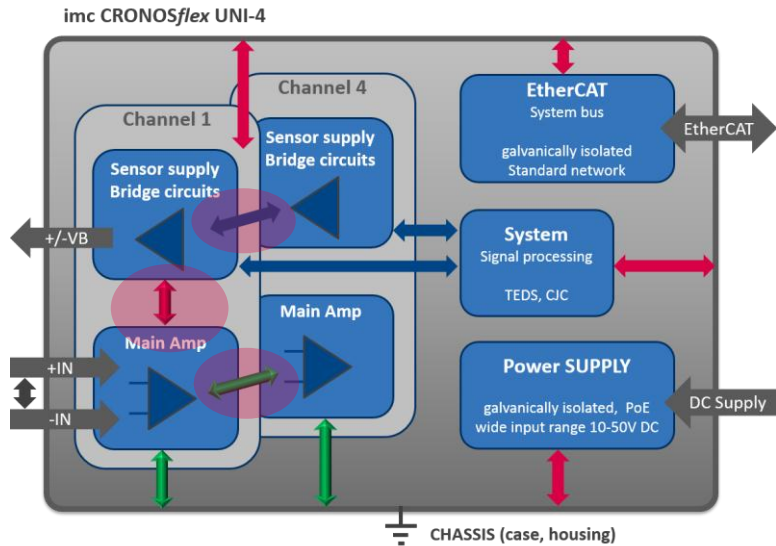

Degree of isolation

- Individual galvanical isolation
- Functional block isolation
- No isolation between components

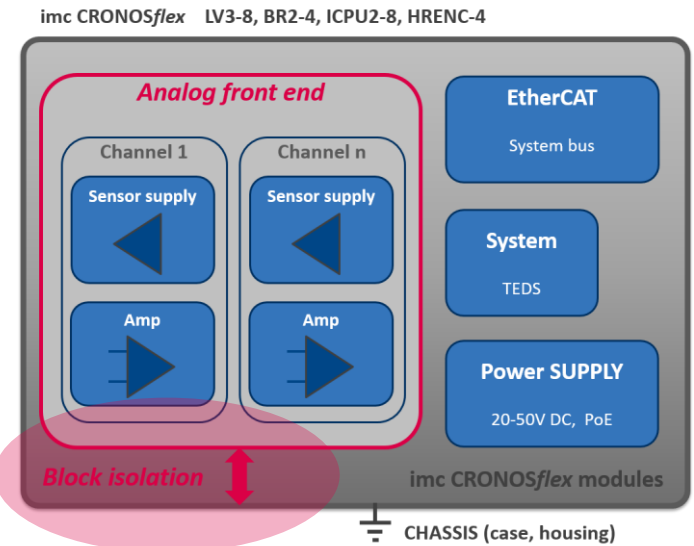

Thank you for your attention.

See you at: www.imc-berlin.com

